

MPC7447A PowerPC® Single Board Computer



APPLICATIONS

The VP 754/20x is a high performance, VME single board computer specifically designed to address the needs of the COTS military and commercial OEM in the embedded real-time marketplace. This includes applications in process control, medical systems and telemetry systems. The VP 754/20x uses the Freescale® MPC7447A PowerPC® Host Processor. The MPC7447A is a

high-performance, 32-bit implementation of the PowerPC RISC architecture combined with a full 128-bit implementation of Freescale's AltiVec™ technology. The board supports a dual EIDE interface, two Gigabit Ethernet interfaces, graphics and four USB interfaces. To simplify the board's integration, board support packages are available for common operating systems.

HIGHLIGHTS

- 1.4 GHz PowerPC MPC7447A Processor:
 - 32 Kbytes L1 data cache
 - 32 Kbytes L1 instruction cache
 - 512 Kbytes L2 cache
 - Freescale AltiVec technology
 - IEEE 754-1985 compliant Floating Point Unit
- Up to 1.25 Gbytes of 266 MHz DDR ECC SDRAM
- 2 x 10/100/1000 Mbps Ethernet Interface
- Dual EIDE interface
- 1 x PMC Module interface (32/64-bit and 33/66 MHz)
- 2 Mbytes battery backed SRAM
- 64 Mbytes Flash EPROM
- High resolution graphics interface
- 2 async/synchronous RS232/422 serial channels
- 6 timers
- Real time calendar/clock
- VME-64 Interface supporting A32/A24/A16/D64/D32/D16/D8(E0), MBLT64
- Single slot
- P2 and P2/P0 Transition modules available
- Extended temperature version available:
 - -25°C to +70°C (E-Series)
 - 1.4 GHz processor operating at 1.0 GHz
- Support for VxWorks®, LynxOS® and Linux®

Central Processor

- Freescale® PowerPC® MPC7447A processor:-
 - operating at 1.4 GHz
 - 64 Kbytes L1 cache
 - 512 Kbytes of L2 cache
 - Freescale AltiVec™ technology
 - IEEE 754-1985 compliant Floating Point Unit
 - 133 MHz CPU bus speed
 - no CPU fan
- Marvell® Discovery™ II (MV64360) PCI Bridge

DRAM

- supporting up to 1.25 Gbytes DDR DRAM:-
 - 256 Mbytes soldered
 - up to 1 Gbyte provided via a 200-pin SODIMM socket
 - supporting 266 MHz DDR ECC SDRAM
- 72-bits wide using 2.5V DRAM
- accessible from PowerPC, PCI and VME bus

Flash Memory

- 64 Mbytes Flash EPROM:-
 - 32-bits wide

Hard Disk Interface

- EIDE Interface:-
 - primary and secondary interfaces via P2
 - up to 4 drives supported
 - up to ATA100 speeds

Ethernet Interface

- 2 x Gigabit Ethernet channels:-
 - 1 channel via a front panel RJ45 and 1 channel via P2 connector (See Note 2)
 - supports 10Base-T, 100Base-Tx and 1000Base-Tx
 - implemented in the MV64360 PCI Bridge

Graphics Interface

- implemented by a Silicon Motion SM722 providing:-
 - 8 Mbytes video memory
 - resolutions up to 1280 x 1024; supporting up to 16M colors
- accessed via a 15-way high-density connector on front panel

PMC Interface

- 1 x PMC site, within a single VME slot:-
 - I/O via front panel
 - 64-bit rear I/O via optional P0 connector (see Note 1)
 - 32/64-bit and 33/66 MHz PCI operation
 - 3.3V signaling

Serial Interfaces

- implemented within the MV64360 PCI Bridge
- 2 x serial interface channels supporting:-
 - 1 x RS232 via a 9-way D-type connector on the front panel
 - both RS232/422/485 channels via P2 connector (see Note 2)
 - asynchronous rates up to 250Kbps
 - synchronous rates up to 4Mbps (SDLC and HDLC)
 - CTS, RTS, DTR, DSR, RI and DCD modem control signals

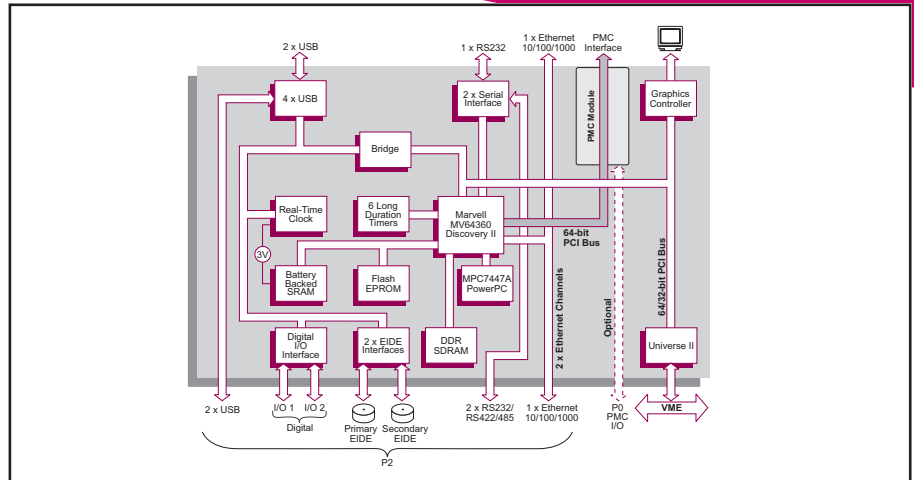

Other Functions

- 4 x USB 1.1 channels:-
 - 2 via front panel connectors
 - 2 via P2 connector
- 6 x user timers:-
 - 4 x 32-bit timers within the MV64360 PCI Bridge
 - 1 x 32-bit CPU Decrementer
 - 1 x 64-bit CPU Time Base
- 2 x digital I/O lines (unbuffered):-
 - accessible via P2 connector
- real time calendar/clock:-
 - with 256 bytes NVRAM
 - battery backed
- diagnostic port for JTAG CPU emulator

Battery Backed SRAM

- 2 Mbytes battery backed SRAM

Software Support

- support for VxWorks, LynxOS and Linux
- LAN boot firmware included

Firmware Support

- PPCBoot for VxWorks, LynxOS and Linux:-
 - supports booting from Flash or Hard Disk
 - supports remote boot over Ethernet

VME Interface

- implemented using Tundra® Universe II™ device connected to 64-bit PCI bus
- VME Master/Slave
- A32/A24/A16/D64/D32/D16/D8(E0)/MBLT64
- auto system controller detect
- full interrupter / interrupt handler support
- 4 x 32-bit mailbox registers
- location monitors

Electrical Specification

- all voltages to be within $\pm 5\%$
- +5V @ 6.8A (typical with 1.4 GHz CPU and 256 Mbytes DRAM)
- +12V @ 0.1A: -12V @ 0.1A
- +12V and -12V routed to PMC Expansion from VME bus

Environmental Specification

- operating temperatures:-
 - 0°C to +55°C (N-Series: 1.4 GHz)
 - -25°C to +70°C (E-Series: 1.4 GHz processor operating at 1.0 GHz)
- -40°C to +85°C (storage)
- 5% to 95% Relative Humidity (operating non-condensing)
- 5% to 95% Relative Humidity (storage non-condensing)

Mechanical Specification

- 6U form-factor single VME slot - front panel width 0.8 inch (20.3mm)
- utilizes a 160-way DIN connector for P1 and P2:-
 - compatible with 96-way DIN connectors
- shock:
 - 20g, 11ms, 1/2 sine (operating);
 - 30g, 11ms, 1/2 sine (non-operating)
- vibration:
 - 5Hz-2000Hz at 2g, 0.38mm peak displacement (operating);
 - 5Hz-2000Hz at 5g, 0.76mm peak displacement (non-operating)

Note 1: variants fitted with P0 connector are supplied with VME64x handles

Note 2: 5-row backplane is required to provide P2 access to Ethernet and Serial Interfaces

ORDERING INFORMATION

Order Number Product Description (Hardware)

VP 754/202-xy 1.0 GHz PowerPC MPC7447A CPU
VP 754/203-xy 1.4 GHz PowerPC MPC7447A CPU

AD VP3/003-00 3-row P2 Transition Module, use where x = 0

AD VP3/003-10 5-row P2 Transition Module, use where x = 0

AD VP3/004-00 5-row P2 Transition Module with P0, use where x = 1

Replace the order number suffix (-xy) with selections from the following:

where x =

0 - 3-row P2 = EIDE, 2 x USB, 2 x GPIO

5-row P2 = EIDE, 2 x USB, 2 x GPIO, 1 x GigE, 2 x Serial

1 - 5-row P2 as for x = 0; P0 = PMC 64-bit rear I/O

where y =

1 - 256 Mbytes

2 - 512 Mbytes

3 - 768 Mbytes

4 - reserved

5 - 1.25 Gbytes

Note: 3-row P2 and 5-row P2 refers to the type of P2 I/O connector required on the VME backplane